



HYDRAULIC CAMPER JACK MAINTENANCE INSTRUCTIONS



965 Lambrecht Road | Frankfort, IL, 60423
Phone: 866.403.9803 | Fax: 815.469.4705
Email: customerservice@riecotitan.com
www.riecotitan.com

For the best operating conditions, keep all parts clean at all times and in open position when not in use. Washers and "O" rings located in five positions on the jack will wear much faster if sand and dirt accumulate. These are easily replaceable in the field.

DISASSEMBLY INSTRUCTIONS

1. Release pressure.
2. Remove two bolts at top of outer tube and one bolt under footplate.
3. Pull head and pressure tube up through outer tube.
4. Slowly loosen packing nut at bottom of pressure tube and drain hydraulic fluid. Remove scraper, "O" rings and scraper in packing nut and install new parts in same order. (SEE NOTE)
5. Pull shaft out of pressure tube and replace snap ring on shaft.
6. Remove pressure tube from reservoir body and replace washer. DO NOT USE WRENCHES ON RESERVOIR BODY.
7. Remove release valve and brass fitting, then replace "O" rings.
8. Remove rivet. DO NOT REMOVE PLUNGER BODY!
9. Slide plunger out of plunger body. Replace the two "O" rings. Put hydraulic oil on tip of plunger and turn clockwise when reinserting.
10. The jack is now ready for reassembly. Follow these same steps in reverse; when ready to refill, use RED AUTOMATIC TRANSMISSION FLUID. Open brass/needle release valve four full turns or open steel knurled release valve one full turn. Fill through fill hole in reservoir body with jack fully closed. This takes approximately 19 ounces of fluid.

Rieco-Titan no longer makes hydraulic jacks. Please call or email with any troubleshooting, repair, or replacement questions.



965 Lambrecht Road | Frankfort, IL, 60423
Phone: 866.403.9803 | Fax: 815.469.4705
Email: customerservice@riecotitan.com
www.riecotitan.com

HYDRAULIC CAMPER JACK MAINTENANCE

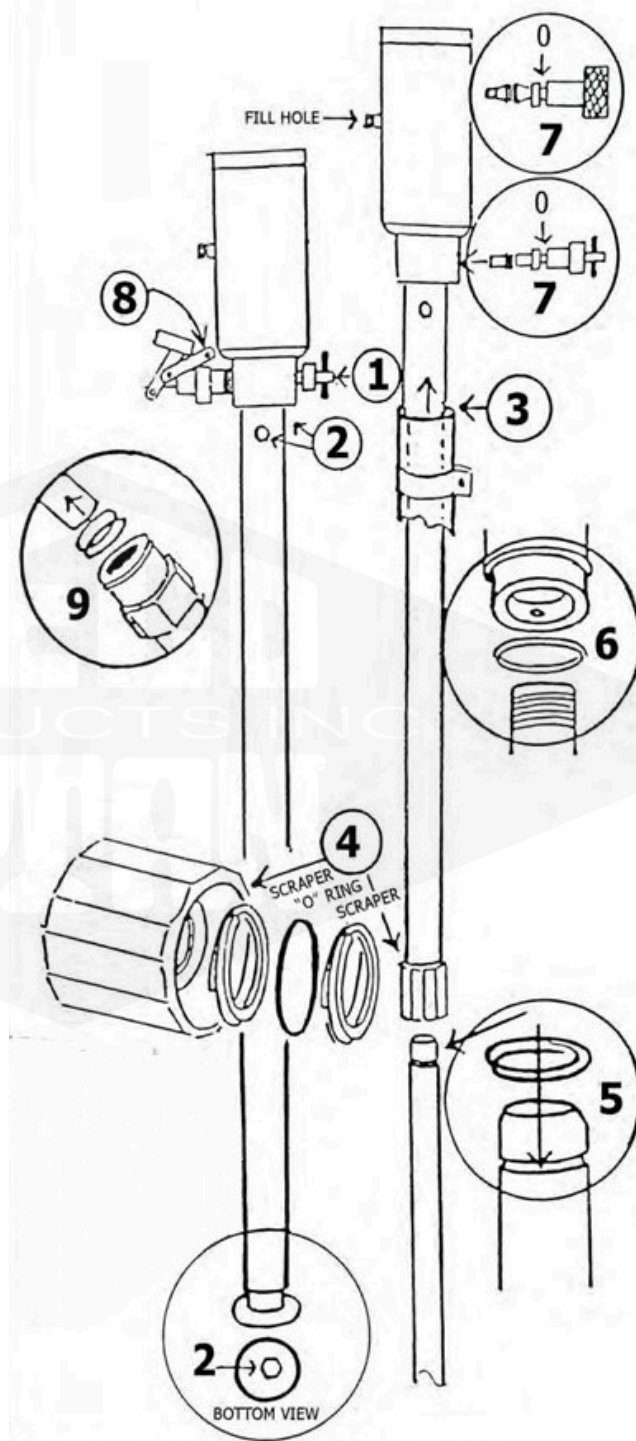

NOTE:

There are two types of PACKING NUTS. TYPE 1, as illustrated in FIG. (4) has a scraper in the groove. The washer is put on each end of pressure tube. TYPE 2, not illustrated, has an "O" ring and a scraper. REPLACE PARTS THE SAME WAY AS REMOVED.

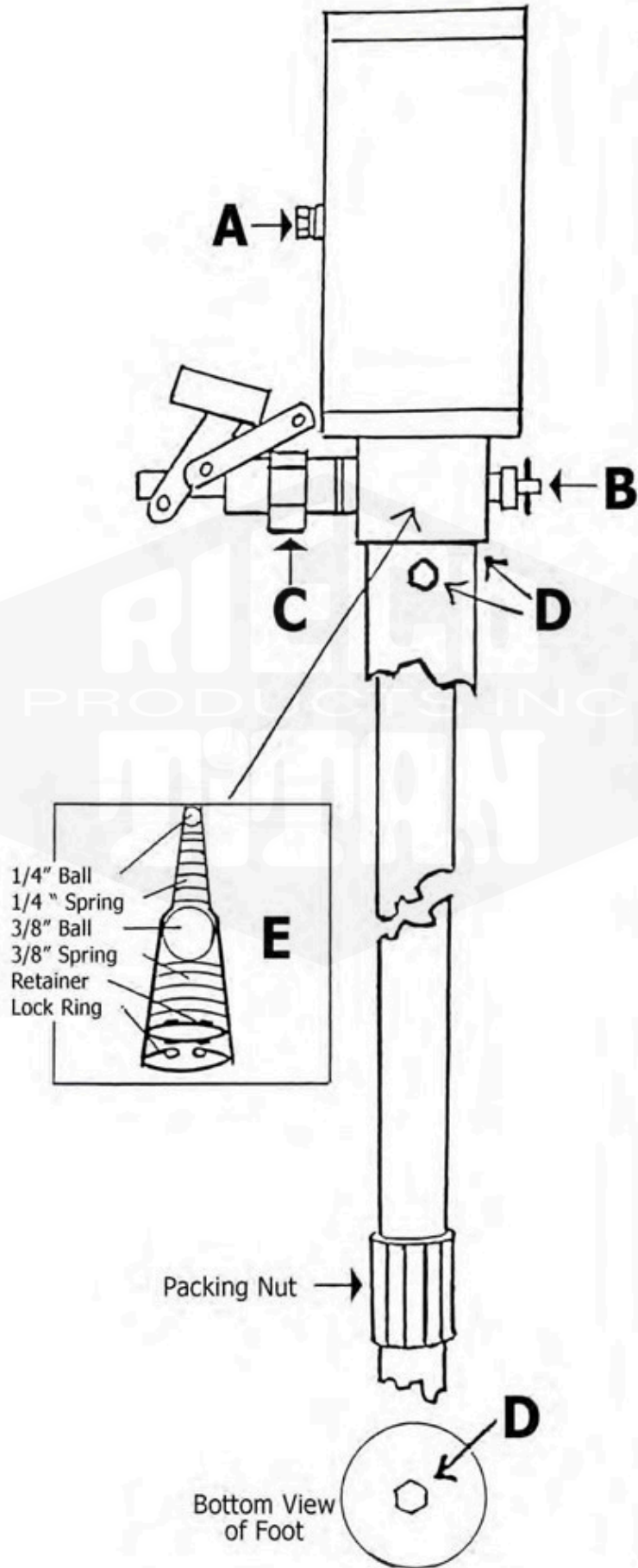

965 Lambrecht Road | Frankfort, IL, 60423
 Phone: 866.403.9803 | Fax: 815.469.4705
 Email: customerservice@riecotitan.com
www.riecotitan.com

CAMPER JACK MINOR REPAIR SUGGESTIONS

A. If a leak occurs at the fill hole screw; loosen screw and replace "O" ring. Do not over tighten or you might strip threads.

B. If leak occurs at the release valve or if jack starts to fade, lay jack flat with valve pointing up. If you have the steel knurled knob release valve, remove it, replace "O" ring and reassemble. Brass valve requires very little tightening.

C. If leak occurs on plunger body; tighten plunger body with crescent wrench about one half turn until very tight. This will stop leakage around plunger body threads.

D. If leak occurs at foot of jack; remove the two bolts at top of outer tube and one bolt under footplate. Pull head and pressure tube up through outer tube. Tighten packing nut at bottom of pressure tube and reassemble.

E. If jack won't pump; remove the bolts at top of outer tube and one bolt under foot plate. Pull head and pressure tube up through outer tube. Close valve and extend shaft. Remove pressure tube from reservoir body, keep shaft lower than head so oil stays in pressure tube. Turn head upside down. Remove lock ring and retainer. Remove springs and balls. Replace with new parts as illustrated in Figure E. Screw head on pressure tube and tighten packing nut at bottom of pressure tube. Test jack to make sure it is pumping, then reassemble outer tube.



965 Lambrecht Road | Frankfort, IL, 60423

Phone: 866.403.9803 | Fax: 815.469.4705

Email: customerservice@riecotitan.com

www.riecotitan.com