



HYDRAULIC CAMPER JACK INSTALLATION & OPERATING INSTRUCTIONS



965 Lambrecht Road | Frankfort, IL, 60423
Phone: 866.403.9803 | Fax: 815.469.4705
Email: customerservice@riecotitan.com
www.riecotitan.com

How to Install Hydraulic Camper Jacks

1. Mount the brackets on the four outside corners, starting with the two front brackets. Mount top of rear brackets same height as top of front brackets. (Fig. 1)
2. Mark, saw, and remove bracket length of trim strip which will be replaced by the brackets.
3. Tap down ribbed aluminum with mallet so brackets will draw tight to coach.
4. Place a thin strip of sealer compound on each side of corner and across top of brackets.
5. Mount brackets so that the thick flat side of brackets extend away from the front and rear of the camper. (See Fig. 2)
6. Caution should be taken so as not to twist off screw heads or strip threads in wood.
7. Tap down brackets and then drill holes with a 5/32" drill and turn in screws on alternate sides of brackets. Tighten all screws.
8. Retighten screws in brackets after after lifting camper a few times.
9. Place the flat portion of the bracket between the two flanges of the clamp that is on the jack and insert a bolt through the holes of the clamp and bracket. **BE SURE TO PLACE A FLAT WASHER UNDER THE BOLT HEAD AND UNDER THE NUT.** Tighten Just enough to keep Jack from slipping.
10. Adjust the jack to the desired height. Repeat step No. 9 for the bottom of the clamp. Rotate jack so that the handles face forward and toward the center on front jacks and back and toward center on rear jacks.
11. Repeat steps 9 and 10 for the remaining three jacks, adjusting the rear jacks the same height as the front ones and **TIGHTEN ALL NUTS SECURELY.**
12. **PRIME ALL JACKS BEFORE USING BY THE FOLLOWING STEPS:** Open release valve one turn, unlock safety latch at bottom, push leg to ground and push back up, do this three times. Then with leg in the down position, close valve tightly and start to pump.
13. After removing camper from truck, set on blocks or on ground. Use jacks or stabilizers. **THESE JACKS ARE FOR LOADING AND UNLOADING ONLY. NOT FOR PERMANENT STORAGE OR USE WHILE CAMPER IS IN RAISED POSITION.**



965 Lambrecht Road | Frankfort, IL, 60423
Phone: 866.403.9803 | Fax: 815.469.4705
Email: customerservice@riecotitan.com
www.riecotitan.com

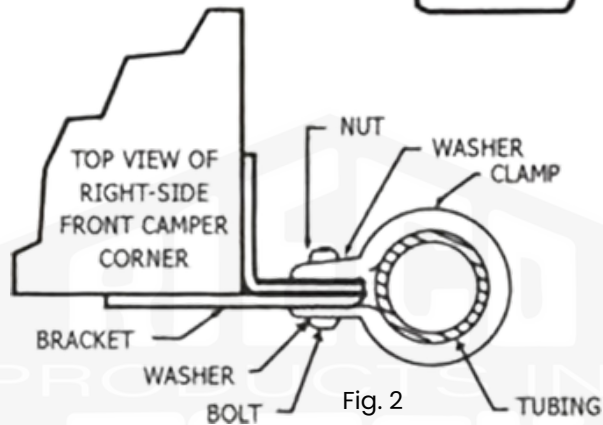
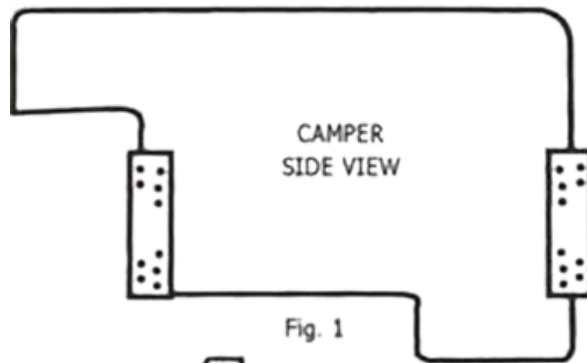

OPERATING INSTRUCTIONS

SAFETY FIRST!

1. Never allow the camper to be occupied while it is being loaded or unloaded.
2. **NEVER RAISE THE REAR OF THE CAMPER HIGHER THAN THE FRONT OF THE CAMPER.**
3. Always check to be sure that all tie-down devices and electrical devices are disconnected from the vehicle body.
4. Do not load camper on a windy day. The amount of wind that is dangerous depends on your exposure, weight of camper, etc.
5. Only unload, load, or store your camper on level ground.

UNLOADING THE CAMPER

1. Open release valve control $1/2$ to $1-1/2$ full turns. **DO NOT OPEN ANY FURTHER.**
2. Remove safety latch from base pad, and release thumb screws.
3. Push base pad to ground and be sure pad has solid footing to prevent tipping or sinking.
4. Repeat same procedure on all four (4) hydraulic jacks.
5. **CAUTION!** Again check and inspect that all tie-downs and electrical devices are disconnected from vehicle body.

6. Close release valve and insert pump handle. Now pump handle lever until camper starts raising; then stop and repeat this same procedure on all four (4) jacks. Always start with two (2) front jacks; never the rear.
7. Raise the front two jacks 3" to 4" only. Then raise the rear two jacks until the camper is level with the front. **ALWAYS BE SURE THAT THE FRONT OF THE CAMPER IS NEVER LOWER THAN THE REAR. THE CAMPER MUST ALWAYS BE LEVEL, OR THE FRONT HIGHER THAN THE REAR.**
8. Continue with the above lifting procedure until the camper is approximately 6" above the truck bed or until it clears the highest point of the truck bed. Adjust all units by additional raising of each unit to compensate for uneven ground surface.
9. Slowly drive the truck forward taking care not to hit or rub the camper Jacks or wheel wells.

LOADING THE CAMPER

1. Close all release valves and release all thumb screws.
2. Raise the front two jacks 3" to 4" only. Then raise the rear two jacks until the camper is level with the front. **ALWAYS BE SURE THAT THE FRONT OF THE CAMPER IS NEVER LOWER THAN THE REAR. THE CAMPER MUST ALWAYS BE LEVEL, OR THE FRONT HIGHER THAN THE REAR.**
3. Continue with the above lifting procedure until the camper is approximately 6" above the truck bed or until it clears the highest point of the truck bed. Adjust all units by additional raising of each unit to compensate for uneven ground surface.
4. Cautiously back the truck under the camper, make sure you are aligned so as not to hit or rub the camper jacks, wheel wells or fenders.
5. To lower camper to truck body, open release valve 1/4 to 1/2 full turn. No more. Always drop rear of camper first about rot. 4" at a time. Always lower the rear jacks first, then the front Jacks until level with the rear, then lower the rear jacks again. Continue with this procedure until the desired height is reached. Be careful when lowering jacks.
6. Secure camper to truck body. Then open release valves 1 1/2 to 2 turns, push base pads all the way up to external tube. Snap safety latch into notches on base pad and tighten thumb screw for traveling. Leave release valves open 1/4 turn.

LOWERING CAMPER TO GROUND LEVEL

1. Make sure jack has pressure, than release thumb screws.
2. Open release valve v slow! and start by lowering rear jacks. Always drop the rear of the camper first about 3' or 4" at a time. Always lower the rear jacks first, then the front jacks until level with the rear, then lower the rear jacks again. Continue with this procedure until the desired height is reached. Be careful when lowering jacks.
3. When camper is in its final resting position, CLOSE ALL RELEASE VALVES. Remove handle for storage.

CAMPER STORAGE

Do not use the jacks for storage of camper. Camper should be lowered and stored on a sturdy base.



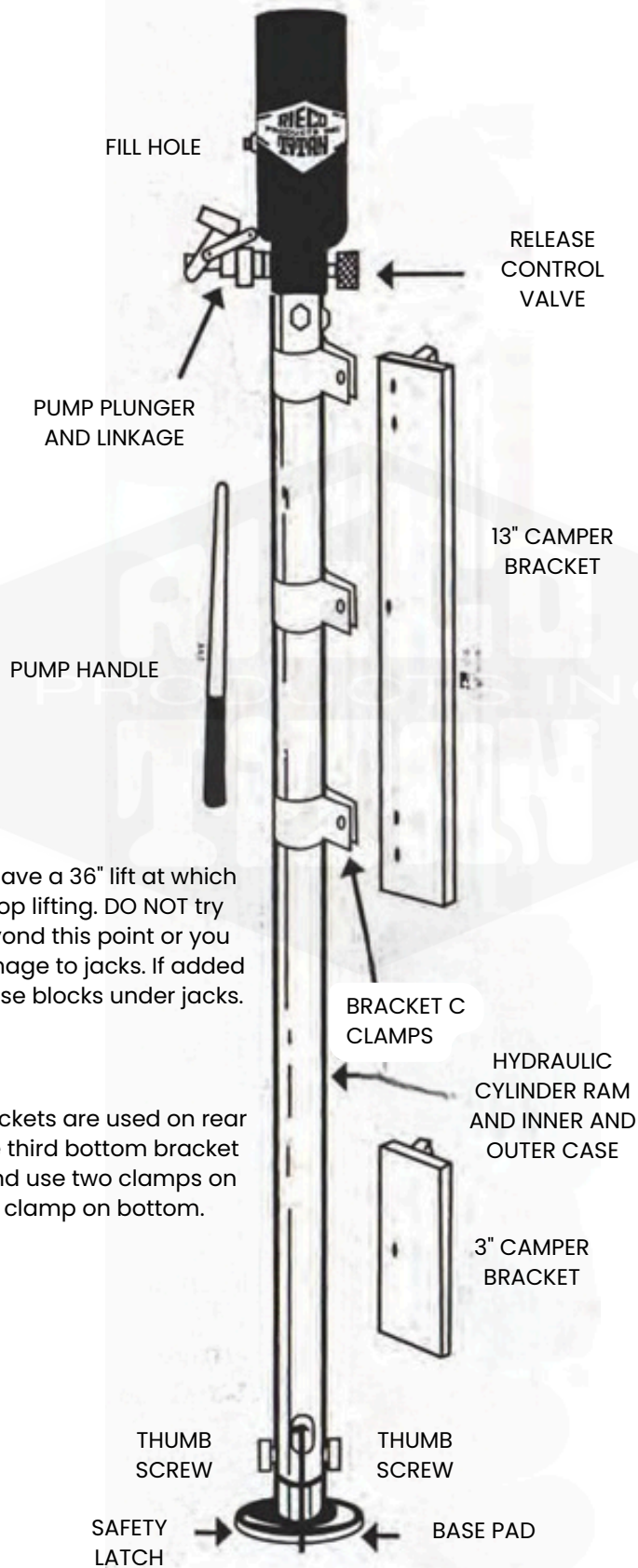

These Jacks have a 36" lift at which point they stop lifting. DO NOT try pumping beyond this point or you will cause damage to jacks. If added lift is needed use blocks under jacks.

If 5" camper brackets are used on rear of camper slide third bottom bracket clamp down and use two clamps on top and one clamp on bottom.



- PARTS LIST -

Part No.	Description	Part No.	Description
RHY-1A0	1 Hydraulic Jack Post	RHY-58	Pressure Tube
RHY-10	Complete Head	RHY-59	Shaft
RHY-11	14 " Std. T Bracket(2-1/2 wide)	RHY-61	Plunger Tube
RHY-25	14 " H.D. T Bracket(3-1/2 wide)	RHY-62	Plunger Bar
RHY-12	C-Clamp	RHY-65	Release Valve-Knurl
RHY-13	Hardware Bag (Set of 2)	RHY-65-N	Release Valve 2 Piece
RHY-15	Pumping Mechanism	RHY-66	Neopreme Button
RHY-16	Handle	RHY-68	Packing Nut
RHY-17	Lag Screw	RHY-69 Sm	Stainless Steel Small Bale
RHY-18	5/16x24 x 1/2 Hex Head Screw	RHY-69 Lg	Stainless Steel Large Bale
RHY-55	Outer Tube	RMK-2	Maintenance Kit (Repairs 2 Jacks)
RHY-57 Lg	Inner Tube w/Large Footpad		

- SAFETY & MAINTENANCE RECOMMENDATIONS -

VERY IMPORTANT!

1. Do NOT load camper on windy day. The amount of wind that is dangerous depends on your exposure, weight of camper, etc.
2. Only unload or store your camper on level ground.
3. The jacks are only to load, unload or steady your camper. Never use these jacks to store your camper.
4. Do NOT extend jack beyond red safety line in inner tube.
5. **NEVER LET THE REAR OF THE CAMPER BE HIGHER THAN THE FRONT OF THE CAMPER.**
6. Inspect and maintain your jacks regularly. Especially the bolt under the footplate. If this bolt is not there, replace with a 5/16 x 24 x 1/2 HEX HEAD BOLT.
7. Occasionally, when jacks have not been used, the check ball system in the jacks will stick. Follow steps 1 & 2 of HOW TO PRIME JACKS on page 1. If this procedure does not work, tap the bolts on each side of the jack with a hammer, just below the black head, several times, followed by steps 1 & 2.

LIMITED WARRANTY

The RIECO•TTAN PRODUCTS, INC., Hydraulic lack is warranted against manufacturing defects and workmanship for one (1) year from date of purchase. Within this period, RIECO•TITAN PRODUCTS, INC., will at its option, repair or replace the product or any part thereof without charge for parts and labor. To exercise the warranty, the product and original invoke must be returned to RIECO•TITAN PRODUCTS INC., freight prepaid and Insured.

This warranty does not apply In the following cases: improper installation, misuse, failure to follow Installation and operating instructions, alterations, abuse, tampering or accident.

AU statements, technical information and recommendations contained herein are based on tests we believe to be reliable, but the accuracy or completeness thereof is not guaranteed, and the following is made in lieu of all warranties expressed or implied. Sellers and manufacturers only obligation shall be to replace such quantity of the product proved to be defective In accordance with published Warranty Policy. Neither seller nor manufacturer shall be liable for any injury, loss or damage, direct or consequential arising out of the use or the inability to use the product. Before using, user shall determine the stability of the product for his Intended use, and user assumes all risk and liability whatsoever in connection therewith.

Except as provided herein, RIEC•ITAN PRODUCTS, INC., makes no express warranties and any implied warrant of merchantability of fitness for a particular purpose is limited to the duration of the written limited warranties set forth herein.

There will be charges rendered on repairs to the product made after the expiration of the aforesaid one year Warranty Period.

RIECO-TITAN PRODUCTS, INC. 965 LAMBRECHT RD, FRANKFORT, IL 60423- (815)464-7400 FAX (815)469-4705





HYDRAULIC CAMPER JACK OPERATING INSTRUCTIONS

BEFORE INSTALLATION

While all Hydraulic Camper Jacks are primed and tested before boxing, some jacks may lose their prime after leaving the factory. We therefore recommend following the undernoted procedure, before installing.

1. Open release valve one full turn.

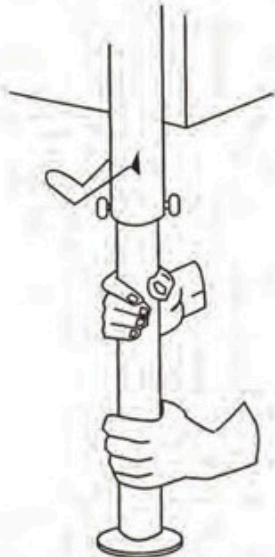
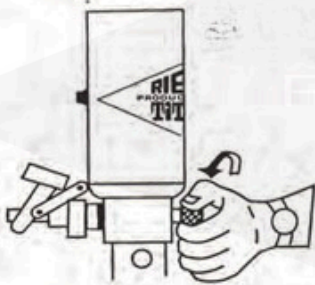

HOW TO PRIME JACKS BEFORE MOUNTING

2. Unlock wire base on foot plate and loosen set screws.

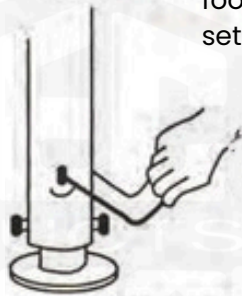

3. Place your toe on foot plate, take hold of Jack with both hands and lift up Jack then push down. Do this three or four times to flush complete system.

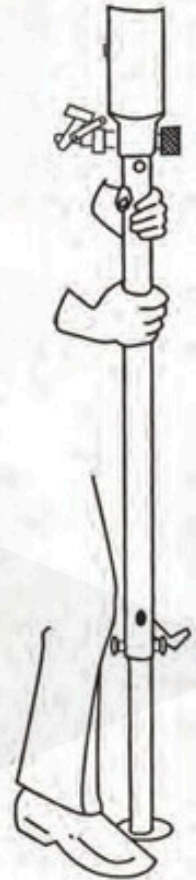

4. Close release valve tightly and pump Jack to be sure everything is working before mounting.

HOW TO PRIME JACKS AFTER MOUNTING

1. Follow steps 1 and 2.
2. Take hold of inner leg and pull down to ground, push leg back up. Do this three or four times to flush complete system.
3. With the foot plate on the ground, close valve tightly and start to pump. When Hydraulic Jacks have not been used frequently, they tend to get sticky inside and need to be primed or flushed in this manner.

